



# DODGE 47/48 DIESEL TRANSMISSION



**SunCoast Converters, Inc.** was established in 1989 as a two-man operation in the back of a transmission shop. Today, SunCoast has grown to over forty employees and over 70,000 sq. ft. of room to conduct operations. SunCoast started with a quest to answer the demand for quality after-market torque converters, transmissions, and parts.

Since then, SunCoast has identified and corrected failure points within numerous OEM transmissions and torque converters. SunCoast formulates test data using real-world scenarios, along with the latest technology and design methods, to manufacture parts that correct the cause of these failures. This practice has helped SunCoast stay ahead of its competitors in not only quality, but also extending past that to the winner's podium for its customers and sponsored vehicles. The company's research and development, combined with years of transmission and torque converter experience, is unparalleled.

Pride in design, manufacturing, technical support, and customer satisfaction has been and always will be the primary goal of SunCoast. The company tries to educate the public on the differences in products from other manufacturers, mainly so its customers know when they are getting product of substance versus a product that is simply relabeled. SunCoast will never sacrifice quality for price point. They have numerous CNC machines that run around the clock making parts for in-house use. They also have multiple CAD developers, as well as programmers on staff, making innovation in design second nature.

SunCoast is known throughout the transmission world for its top-of-the-line torque converters, transmission and rebuild kits because the company has taken the time to listen, learn, research, and respond to its customers' suggestions, with outstanding results. The company will continue to make its converters and transmissions the best in the business, while continuously researching new technologies that shine new light on the industry. Design copying is easy. Innovations, however, are more difficult.





## **NOTICE: READ THIS**

**If the MANUAL cable linkage (all) 1996-2006 and TV cable linkage (04 & earlier) is not adjusted properly you will destroy the friction elements.**

**The installer is responsible to make the proper adjustments.**

**Failure to assure proper adjustments will void any warranty considerations.**

If you really want to nail it down, hook up a pressure gauge to accumulator port. Observe line pressure gauge to accumulator port. Observe line pressure in drive (80#) line pressure Must disappear (go to absolute 0) when lever is moved to Neutral, Reverse & Park.



## SunCoast 48RE 618 Transmission Installation

### Please read this!

03 And later dodge trucks have a cable operated gear selector mechanism. A maladjusted cable can allow the manual valve to be held between detents. If this occurs in the park position the manual valve will allow converter feed oil to enter the forward clutch circuit at a reduced pressure. This condition will allow the forward clutch to drag (partial apply) while in park. If the vehicle is left running in park for other than a short time or the engine is revved the forward clutches will be damaged. Please take a few minutes to properly adjust the cable after any repairs are performed on the transmission. This few minutes can save hours of grief and needless repairs.

1. Shift the transmission into park
2. Release cable adjuster lock tab (underneath the steering column-fig 110) to unlock cable
3. Raise vehicle
4. Disengage the cable eyelet from the transmission manual shift lever
5. Verify the shift lever is in park detent by moving lever rearward. Last rearward detent is park position. 6. Verify positive engagement of transmission park lock by attempting to rotate propeller shaft. Shaft should not rotate in park position.
6. Snap cable eyelet onto the transmission manual shift lever.
7. Lower vehicle
8. Lock shift cable by pressing cable adjuster lock tab downward until it snaps in place.
9. Check engine starting in park and neutral
10. Engine should rev freely in park or neutral

Fig. 110 Gearshift Cable at Steering Column

1. Steering Column
2. Gearshift Cable
3. Gearshift Cable Lock Tab
4. BTSI Connector

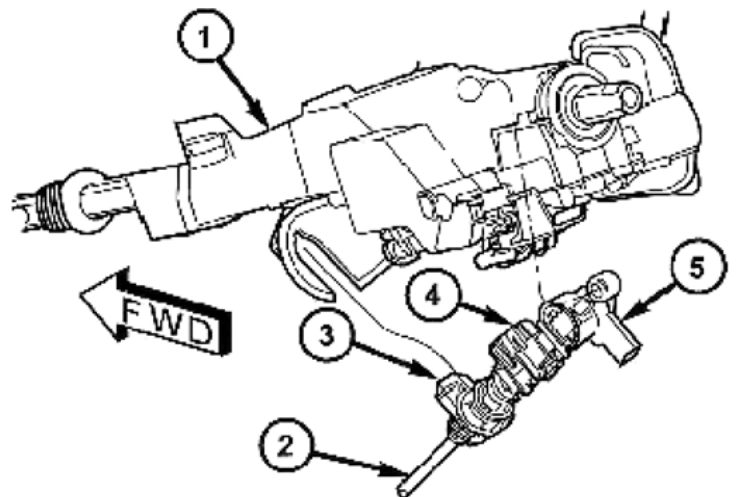



## 24V ISB T.V. CABLE ADJUSTMENT



Remove plastic cover over throttle linkage, locate kick down cable, disconnect and remove from bracket.



Mark cable at original setting. Remove white plastic locking clip. (Do not break clip not available separately.)

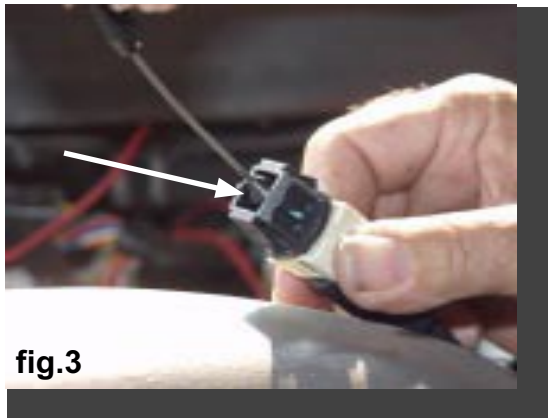

Adjust cable to protrude approximately 3/16. Install clip, reinstall in bracket and onto throttle lever.

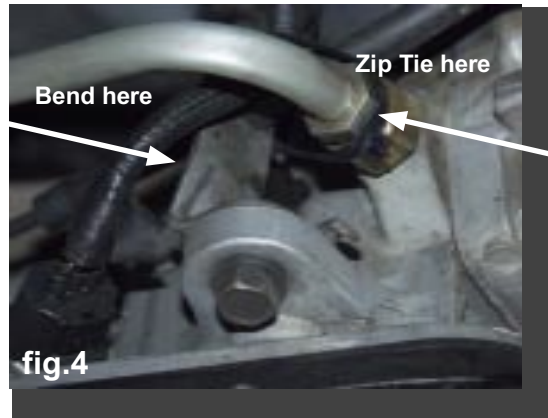

Have someone floor board pedal. Check for slack in cable. (fig. 1) If cable is slack bend bracket on trans toward rear of vehicle. (fig. 4) Secure cable to cooler line with zip tie.

**You now have max T.V. If upshifts are too late adjust cable housing towards front of truck in 1/8" increments until desired shift points. Reinstall plastic cover**



## SUNCOAST ADDITIONAL INFORMATION

To prevent forward clutch burn up and reduce drain back, ALWAYS check/adjust shift linkage. Here is how to check it: Place the selector in reverse. Then gently move selector "P". Now, check the Shifter Arm on the side of the trans by trying to move it rearward. If it moves rearward, adjust linkage.

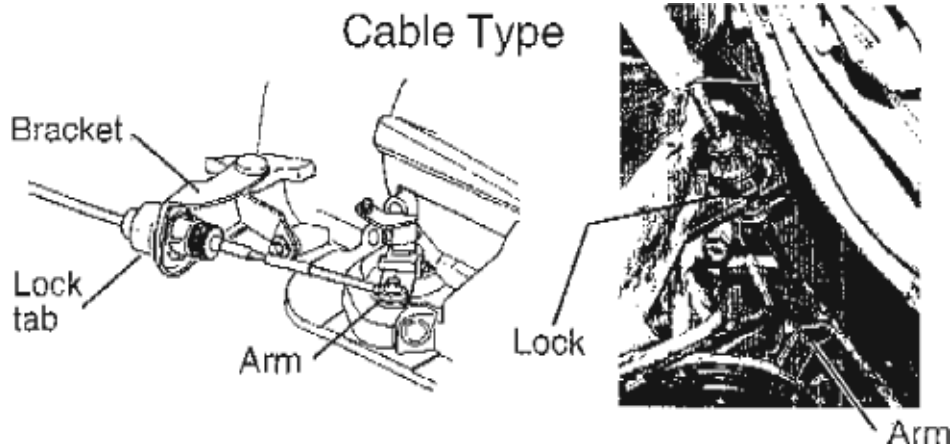

With selector in "P". Arm must be ALL the way rearward. It must not move further when you push on it. Cable Type: You may find it necessary to bend the bracket slightly to get a perfect adjustment.

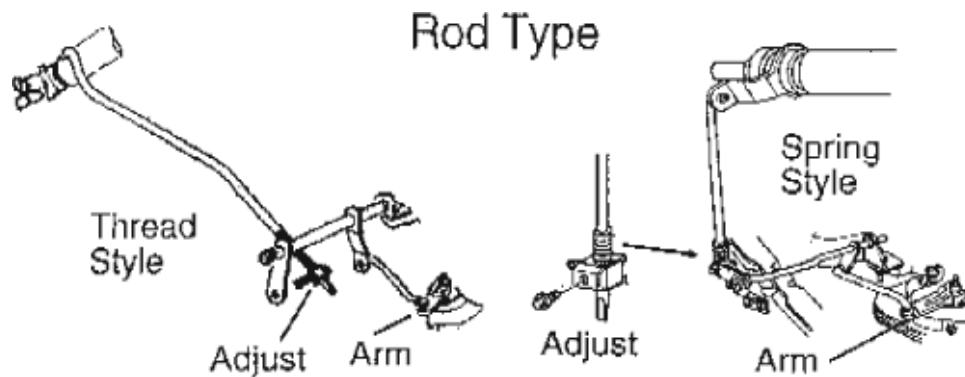



## SUNCOAST FLYWHEEL INSPECTION

### NOW IS THE TIME

**Dowel Pin & Flywheel Inspection with the transmission removed.**

**Remove flywheel, inspect for cracks.**

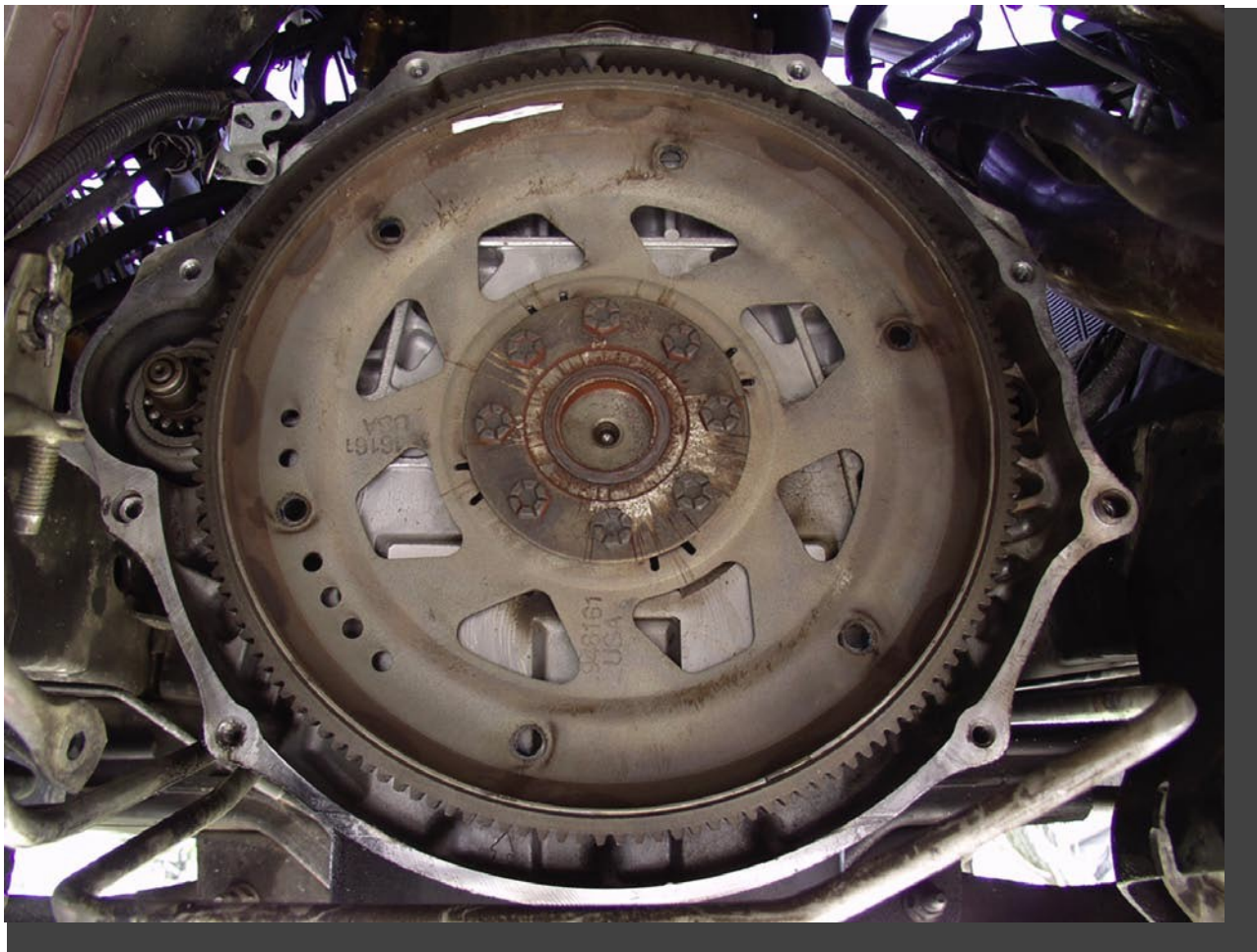

#### **Dowel Pin Missing**

Make sure both dowel pins are present. Missing dowel pin or pins cause severe damage to converter and or pump.

#### **Dowel Pin**



## **BEFORE INSTALLATION OF YOUR NEW SUNCOAST TRANSMISSION PLEASE FOLLOW THESE INSTRUCTIONS:**

**Once the old transmission is removed check the following:**

- 1. Make sure both dowel pins are still in place in the motor plate.**

This will insure correct alignment for your new transmission. Failure to make sure both dowel pins are in place can cause premature transmission failure that will not be covered under warranty.

- 2. Clean all electrical connections to the transmission and/or transfer case.**

A loose or improper electrical connection can cause premature transmission failure that will not be covered under warranty.

- 3. Check all u-joints, carrier bearing and motor mounts.**

Bad u-joints, carrier bearing, and motor mounts can cause premature transmission failure and/or cracks in the transmission and transfer case. Failures and/or cracks are not covered under warranty if caused by bad u-joints, carrier bearing and/or motor mounts.

## **SUNCOAST HOT FLUSH PROCEDURE**

**Once the old transmission is removed the cooler and lines must be flushed for your Suncoast warranty to be valid.**

In house Suncoast uses a Hot Flush machine. Using hot oil and reversing the flow for a microsecond is the only way to dislodge foreign material from the cooler. This is the only approved method of flushing your cooler and lines.

**Failure to properly flush trans oil cooler system will result in erratic operation and premature failure.**

**NOTE: If a warranty claim is started and you did not flush your cooler and lines, your warranty will be denied.**





## SunCoast Flexplate

If you purchased your transmission with a SunCoast billet flex plate, refer to factory specs when torquing the flex plate bolts. Also leave any spacers that were with the factory flex plate off.

## SunCoast Torque Converter Bolts

If you purchased your transmission with a Suncoast torque converter you **MUST** use the supplied bolts with our converter. Failure to do so will cause damage to the torque converter that will not be covered under warranty

## SunCoast Recommended Service Intervals

**The following service intervals can vary based on the use of the truck.**

Every 35,000 miles Suncoast recommends fluid and both filters be serviced.



## SunCoast-Recommended Transmission Fluid

### SC-TYPE-D ATF

SunCoast recommends our proprietary full synthetic transmission fluid in all SunCoast transmission builds.

#### Features and Benefits Include:

- Outstanding low temperature performance and sheer resistance
- Dramatic improvements in thermal stability during endurance environments
- Optimized frictional properties that can provide smoother shifting during low temperature operation, reducing shudder and vibration
- Outstanding resistance against sludge and deposit formation
- Improved anti-wear protection, which directly contributes to extended transmission life
- Unsurpassed low temperature stability
- Resists foaming and thereby promotes outstanding operability

Throughout the years, SunCoast has put enormous effort into the research and development of failure prevention in some of the most extreme environments that exist today. These environments are not limited to hot shot driving, sled pulling, drag racing, and the Texas Mile.

For our own success and growth, it has been imperative that oil analysis be our measuring stick for improvements. We can use this to determine the amount of degradation that transpires during a drive cycle. This is key when we are determining what friction coefficients work best in a particular application. This process has evolved with both the friction material and fluid types.

As technology has evolved, so has transmission fluid. Here at SunCoast, we have been on the leading edge of this development. We have seen the evolution from the original Dexron that was introduced back in the late 60's, that utilized sperm whale oil as a friction modifier; to the early 70's when Jojoba oil was introduced, along with corrosion inhibitors, making it hygroscopic. Fast forward to today and the evolution continues.

SunCoast has known for quite some time that we have more success with certain fluids than others. There is a science to the madness, and we knew it was in our best interest to ensure we understood this. In 2006, when General Motors released Dexron VI it set a new standard within the industry. Through our independent testing, we were able to verify that this was an improvement over anything we had seen to date. This is when SunCoast made the decision that this was an area we should become more familiar with, knowing this is how we are protecting our units. Since 2006, SunCoast has spent countless hours reviewing data from oil samples that we have sent in for testing, in an attempt to figure out what works best for our environments.

This new full synthetic transmission fluid contains all of the prescribed combination additives that improve the lubricating qualities for your high stress transmission. The specialized additives include anti-wear, rust and corrosion inhibitors, detergents, dispersants, and surfactants (surfactants protect and clean metal surfaces). In addition, we have also added very specific viscosity modifiers, seal and swell additives, and anti-foam additives. This fluid has yielded us the best test results to date and offers uncompromised performance. We are also proud of the fact that this fluid is full synthetic, not a blended fluid as so many others have attempted to pass off. The SunCoast Type-D Full Synthetic transmission fluid also has a slightly lower viscosity at lower temperatures than the competitor's fluid, decreasing parasitic drag during normal driving conditions. This, of course, requires the use of higher-quality, more sheer stable base oil compounds when manufacturing. Rest assured, with this new full synthetic fluid you are getting the absolute best protection on the market today.



## Transmission Fluid Fill Procedure Fluid Capacity

Stock Pan – 16 Quarts + or – 1

Deep Pan – 20 Quarts + or – 1

To avoid overfilling the trans, perform the following:

- Remove the dipstick.
- Add approximately 10 quarts for stock pan or 14 quarts for deep pan.
- Apply the parking brake.
- Start and run engine at normal curb idle speed.
- Apply service brakes, shift trans to NEUTRAL, set the parking brake, and leave engine running at curb idle speed.
- Add fluid until the fluid is at the MAX arrow mark.
- Insert dip stick and check fluid level. If level is low, add fluid to bring level to MIN mark on the dipstick. Make sure to check that both sides of the dipstick are level. If one side is noticeably higher than the other, the dipstick has picked up some oil from the dipstick tube. Allow the oil to drain back down the tube and re-check.
- Shift the trans while the parking brake and service brakes are applied from DRIVE TO REVERSE 4 to 5 times. Then shift back to neutral.
- Re-check the fluid level on the dipstick.
- Drive the vehicle until transmission fluid is at normal temperature.
- With engine running at curb idle speed, move the gear selector to NEUTRAL, and the parking brake applied, re-check the transmission fluid level.

**CAUTION:** Do not overfill the transmission, fluid foaming and shifting problems can occur!

When fluid level is correct, shut off the engine, release the park brake and install the dipstick in the fill tube.



**BREAK-IN PERIOD OF**

**500-MILES**

**REQUIRED**

**FOR WARRANTY TO BE VALID**

Do this in stop and go @ light to medium throttle openings before any high throttle up-shifts are made.



## SHIPPING YOUR TRANSMISSION & CONVERTER

- Both the transmission and converter were included with a bag. Both are to be placed inside the bags for you to receive your full core credit.
- Fluid leakage will not be tolerated.
- You must drain both the transmission and torque converter prior to shipping back to SunCoast.
- Plug all holes with the red caps that plugged the holes of your new unit.
- If your trans and converter was shipped in a tote just put the bagged trans and converter inside and tighten the straps. Place the lid on top and secure with the supplied clips.
- If your trans and converter was shipped on a pallet place the bagged trans and converter on the pallet and secure with metal strapping. If the trans and converter are improperly secured you will be responsible for any damage cause during shipping.

DO NOT ship your converter back with it still inside the trans. This will cause damage if not secured properly and you will be responsible for any damage that occurs.



## CORE RETURN INSTRUCTIONS: READ THOROUGHLY!

All cores must be returned within 45 days to receive full core credit! Cores returned after 6 months without prior approval are subjective to no core credit! Once your core return is delivered to SunCoast, please allow up to 3-4 business days for it to be inspected and checked in and up to 10-15 business days for your credit to be processed and refunded. Most core credits are processed sooner, however the above are worst case.

**\*VERY IMPORTANT! THE FOLLOWING MUST BE FOLLOWED IN ORDER TO RECEIVE YOUR FULL CORE CREDIT IN A TIMELY MANNER. IF ANY OF THESE STEPS ARE NOT FOLLOWED, THEN YOU MAY NOT RECEIVE YOUR FULL CORE CREDIT AND OTHER CHARGES MAY BE APPLIED.**

To return a core to SunCoast, first drain all fluids, if any, from the product.

**\*VERY IMPORTANT! NO SHIPPING CARRIER WILL TOLERATE FLUID CONTAMINATION OF OTHER PACKAGES! DUE TO THIS WE WILL REFUSE TO ACCEPT ANY LEAKING PACKAGES. THEY WILL BE RETURNED TO SENDER AND THE SENDER WILL BE LIABLE FOR DAMAGES, FREIGHT AND LOST CORE DEPOSIT!**

Fill out the Core Return Form found in the box you received your product in. If no form is located or you misplaced the form, please include the following information with your core or download from [www.suncoastdiesel.com](http://www.suncoastdiesel.com):

- If product was purchased from anywhere other than SunCoast Directly, please include Dealer Name
- Your Name
- Original Invoice Number (SunCoast Invoice Number)
- RMA Number
- Original Purchase Date
- Address
- Telephone Number
- Product Part Number

Include the form along with the core in the original packaging and/or box in which your new product was sent.

You will not be reimbursed for shipping costs incurred in shipping the core to SunCoast. To return the core, simply place the product/core in the included plastic bag and secure with included zip tie. Secure the product/core in the tote or on a pallet which ever your product was delivered on. You are responsible for securing the product/core to insure no damage during shipping. Any damage to the product/core due to being improperly secured will be deducted from your core credit.

You can contact SunCoast and we will be happy to arrange your return shipping to insure you are getting the best freight price. However, if you decide to use your own shipping company you will be responsible for all charges regardless of any promotions.

Assuming the core passes inspection, the credit card you used to purchase the new product will be credited in the amount of the core's value as indicated by the inspection. If purchased through a distributor, the credit will be issued to that distributor, who will then issue the credit to you. If the core does not pass inspection, you will not be reimbursed for the core or may only receive partial credit. Please understand that once the credit is processed by SunCoast, the amount of time you receive credit varies depending on your bank.



## CORE RETURN DEDUCTIONS

**The following are deductions on core returns that will be implemented immediately.**

1. Late core returns (Stocking orders after 90 days)
  - After 45 days 15% deduction
  - After 1 year no core return unless prior arrangements are made with Suncoast (Subject to 15% to 85% deduction)
2. Core returned must be equivalent to product purchased (Year, Type, Etc.)
3. Core return paperwork not filled out - \$35.00
4. Converter/Transmission/Valve body, excessive fluid leakage (All products should be drained prior to shipping back to Suncoast)- \$50.00
5. If Converter/Valve body are not returned in the provided bag to contain possible fluid leakage - \$25.00 – This prevents possible UPS/FEDEX re-boxes which will cause delay in core return.
6. If trans is not shipped back inside the included bag to contain possible fluid leakage - \$100.00
7. Transmission core returned with no tote - \$350.00
8. Transmission core returned in tote with no clips - \$10.00
9. Cores returned must be packaged properly. Suncoast is not liable for improper packaging or damage caused during return transit.
10. Broken or unusable cores – Price will vary based on current cost of replacement.

**\*Please allow up to 19 days for core refund to be applied. 3-4 days for inspections and 10-15 days for refund.**







## SUNCOAST DIESEL CORE RETURN FORM

**\*IMPORTANT!** The following must be completed in its entirety in order to receive your full core credit in a timely manner. For multiple cores one core return sheet must be completed for each return. Failure to complete this form or follow core return instructions will cause delays in your return and you will not receive your full core credit. If this form is not completed in its entirety \$35.00 will be deducted from your core credit.

Product Purchased from: \_\_\_\_\_

Your Name: \_\_\_\_\_

Original Suncoast Diesel Invoice Number: (If purchased through another dealer please request Suncoast Invoice number from them to include on this form) \_\_\_\_\_

RMA Number: (Call before sending core and receive an RMA number to put on your paperwork and on the box.) \_\_\_\_\_

Original Purchase Date: \_\_\_\_\_

Your Address: \_\_\_\_\_

Your Telephone Number: \_\_\_\_\_

SunCoast Product Part Number: \_\_\_\_\_

**\*IMPORTANT! Please return cores to:**

**SunCoast Performance  
Attention: Core Returns  
631 Anchors Street NW  
Fort Walton Beach, FL 32548**

**RMA # \_\_\_\_\_**